

P 239

SIGSAUER



Handling and Safety Instructions

Important! Do not discard!

Keep this manual with your firearm.

Upon change of ownership transfer this manual with the firearm.

Table of contents

1	General instructions	2	7	Pistol maintenance	15
2	Safety regulations	3	7.1	Stripping the pistol	15
2.1	Safety indications	4	7.1.1	Stripping the slide	15
3	Product description	5	7.2	Disassembly of the magazine	16
3.1	Main parts	5	7.3	Cleaning the pistol	17
3.2	Main features	6	7.4	Assembling the pistol	18
3.3	Scope of delivery	6	7.5	Verification of functions	19
4	Transporting the pistol	7	7.6	Care of the pistol	20
5	Handling the pistol	7	8	Pistol service and repairs	21
5.1	General remarks	7	8.1	Cause and correction of malfunctions	21
5.2	Initial preparation	7	8.2	Safekeeping and storage of the pistol	23
5.3	Ammunition	8	8.3	Shipping the pistol	23
5.4	Loading the magazine	8	9	Product line	23
5.5	Loading the pistol (ready to fire)	9	10	Disposal	23
5.6	Discharging a shot	10	11	Technical data/types/accessories	24
5.7	Reloading during shooting	11	12	Spare parts	25
5.8	Unloading the pistol	11			
5.8.1	Unloading the pistol, magazine not empty	11			
5.8.2	Unloading the pistol, magazine empty, slide open	13			
6	Sight correction	13			
6.1	Sight correction for windage	13			
6.1.1	Shifting the rear sight	13			
6.1.2	Shifting the front sight	13			
6.2	Sight correction for elevation	14			
6.2.1	Changing the rear sight	14			
6.2.2	Changing the front sight	14			
6.3	Rear and front sight variants	14			
6.3.1	Rear sight variants	14			
6.3.2	Front sight variants	14			
6.4	Rear sight and front sight key	14			

1 General instructions

Be sure to read through these instructions carefully before any manipulation on this SIG SAUER pistol.

Understanding these instructions and the technically correct implementation of the information contained therein are **imperative** to correct preparation and safety during handling, maintenance and care of this SIG SAUER pistol. Do not use the pistol until you have fully understood all safety instructions and its handling procedures. Should you require further information, do not hesitate to contact your dealer, importer or the manufacturer.

Please observe the local and national legislation governing the ownership, carrying and use of firearms.

Be aware that these pistols, like all firearms, are dangerous. The pistol accompanying these Handling and Safety Instructions has been sold under the express understanding that the manufacturer and the importer of the pistol decline any responsibility for consequences of manipulations on the pistol or use of the pistol.

This applies in particular to liability for bodily harm or damage to property resulting in part or in whole to:

- use with criminal intent or negligent use,
- improper or careless handling,
- defective, incorrect, hand-loaded or reloaded ammunition,
- inadequate care of the pistol (e.g. corrosion, damage),
- disregard of malfunctions,
- resale in contradiction of regional legislation and regulations,
- other circumstances beyond our direct and immediate control.

These limitation apply regardless of whether liability is asserted on the basis of contract, negligence or strict liability (including any failure to warn).

The manufacturer and the importer are not liable for incidental or consequential damages such as loss of use of property, commercial loss or loss of earnings and profits.

2 Safety regulations

- Never use the pistol under the influence of alcohol or drugs, during illness or other complaints; they may influence your judgement and reflexes.
- Always consider the pistol as loaded and unsafe until you have verified that it is not by means of the unloading procedure (see Section 5.8).
- During all manipulations, keep the muzzle of the pistol pointed in a safe direction. Safe directions are defined as areas where there are no people, other living creatures or other people's property.
- Never point the pistol at doors, window panes, walls, concrete, stones or other flat surfaces (including water). Shots can penetrate such surfaces or be deflected into unsafe directions by them.
- Never aim at yourself or other living creatures.
- Never rely on safety mechanisms. They are never a substitute for careful and correct handling of the pistol. Safety devices may sometimes be defective or fail. You alone are the best safety device!
- Always handle your pistol as if the safety mechanisms were defective. The best safety device is the correct, well-exercised and secure handling of the pistol.
- Never shoot a pistol into which there has been ingress of water, sand, dirt or other foreign bodies.
- Never decock the hammer by restraining the hammer and simultaneously pulling the trigger.
- Never let a loaded pistol out of your hands.
- Always unload the pistol immediately after shooting, before putting it down, holstering it or handing it to another authorised person.
- Never hand the pistol to any person who has not thoroughly familiarised himself or herself with the safety regulations and handling of the pistol by reading the accompanying regulations and instructions.
- Never leave the pistol unattended and protect the pistol against unauthorised access.
- Never store the pistol loaded, but remove the magazine and verify that there is no round in the barrel chamber by following the unloading procedure (see Section 5.8).
- Always keep the pistol and the ammunition in different places and ensure that neither can fall into the hands of unauthorised persons or children.

Be sure to read through these instructions carefully before any manipulation on this SIG SAUER pistol and that you have understood them.

2.1 Safety indications

In the individual sections of these instructions, the following safety indications alert you to various risks:

	WARNING!
Information on risks which, if not scrupulously observed, can lead to severe bodily harm or death.	

	CAUTION!
Information on risks which, if not scrupulously observed, can lead to bodily harm or damage to the pistol.	

	CAUTION!
Information on technical requirements which, if not scrupulously observed, can lead to damage to the pistol.	

Each safety indication consists of:

- a header with a signal word, icon and a corresponding colour code
- a specification of the type and source of the risk
- a specification of potential consequences if the safety indications are not observed
- specifications of measures and bans designed to avoid risks

Product description

3 Product description

3.1 Main parts

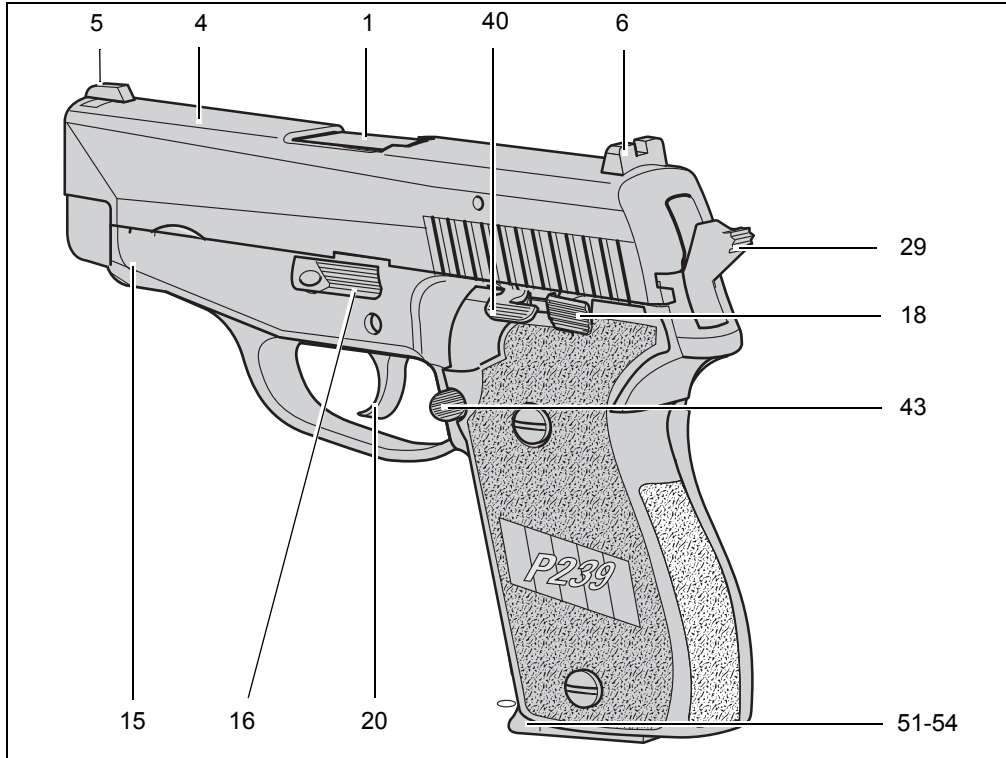

Fig. 1, P 239 (DA/SA version)

Item	Part designation
------	------------------

- | | |
|----|----------------|
| 1 | Barrel |
| 4 | Slide |
| 5 | Front sight |
| 6 | Rear sight |
| 15 | Frame |
| 16 | Takedown lever |

Item	Part designation
------	------------------

- | | |
|-------|------------------------------------------|
| 18 | Slide catch lever |
| 20 | Trigger |
| 29 | Hammer |
| 40 | Decocking lever (only for DA/SA version) |
| 43 | Magazine catch |
| 51-54 | Magazine |

3.2 Main features

SIG SAUER pistols are modern handguns complying with the latest technical advances in weapon design for military, police and sporting use. They operate on the principle of the mechanically locked, recoil-operated pistol with semi-automatic reloading.

The automatic firing pin safety lock, the safety intercept notch at the hammer, the decocking lever and the Double Action trigger ensure safe carrying of the weapon and permanent, rapid firing readiness without actuating a manual safety lock.

The decocking lever makes it possible to decock the hammer without danger into the safety intercept notch without actuating the trigger. During the decocking procedure the Firing pin remains secured by the automatic firing pin safety lock.

The distinctive contrast sights in conjunction with the ergonomically favourable grip design permit rapid, precision target acquisition and firing.

The enclosed design prevents the penetration of dirt inside the weapon.

The P 239 pistol is available as Double Action/Single Action (DA/SA) or Double Action Only (DAO) version, or alternatively as Double Action Kellermann (DAK) version. The DAO and DAK versions are not equipped with a decocking lever **40**.

3.3 Scope of delivery

Included:

- 1 pistol
- 1 magazine
- 1 Handling and Safety Instructions manual
- 1 test group card

Not included:

- Accessories (see Section 11)
- Spare parts (see Section 12)

4 Transporting the pistol



WARNING!

Uncontrolled discharge of shot May lead to death or severe injuries

- For your own safety and for the safety of others, always transport the pistol in the **unloaded condition** (see Section 5.8), **decocked and under lock**.
- Never carry the pistol on your person with a round in the chamber and the hammer cocked.
- Always carry the pistol in such a manner that, should you fall or otherwise slip, you are able to control the direction of the muzzle.
- Transport the pistol separate from the ammunition in a locked carrying case.
- The pistol and ammunition must not be accessible to children and other inexperienced or unauthorised persons.
- Ensure that you comply with all regional and national laws relating to the transport of firearms.

5 Handling the pistol

5.1 General remarks

For preservation, the pistol is normally delivered with a thin coating of protective grease and oils. Before initial preparation, the pistol must be stripped, the protective coatings removed and then relubricated.

5.2 Initial preparation

Procedure:

1. Strip the pistol (see Section 7.1).
2. Clean and relubricate the pistol (see Section 7.3).
3. Assemble the pistol (see Section 7.4).

5.3 Ammunition



WARNING!

Incorrect ammunition

May lead to death or severe injuries and damage to the pistol

- For your pistol, use only commercial grade ammunition in the original packaging, which corresponds to the calibre of the pistol. The correct calibre is stamped on the pistol.
- Only use clean, dry, undamaged and factory new ammunition.
- Never use reloaded, "refurbished", hand-loaded, non-standard ammunition, or ammunition of a different calibre.
- Never use dirty, wet, corroded, bent, damaged or oiled ammunition, or ammunition of unknown origin.
- Never leave ammunition unattended.

5.4 Loading the magazine

Procedure:

1. Place round on feeder **53**, close to the magazine lips.
2. Press round down and push it to the rear.
3. Load the number of rounds that you intend to shoot.

The number of inserted rounds can be checked through the holes of the magazine tube **51**.

5.5 Loading the pistol (ready to fire)



WARNING!

Insufficient awareness of the dangers May lead to death or severe injuries

- Never load or unload the pistol inside a vehicle, inside a building or any other confined space (except in a designated firing range).
- Before loading, always wipe off any excess grease and oil and check that there is no obstruction in the bore of the barrel.
- Always keep the muzzle of the pistol pointed in a safe direction.
- Do not place your finger on the trigger. Place your finger outside of the trigger guard.
- Do not load the pistol by inserting the magazine until immediately before shooting.
- Never pull the hammer back by hand to cock it.
- Never rely on safety mechanisms. They are never a substitute for careful and correct handling of the pistol.
- Never let a loaded pistol out of your hands.

Procedure:

1. Point the pistol in a safe direction.
2. Insert full magazine and check that it engages.
3. Draw back slide to the stop and allow it to fly forward.
 - The pistol is loaded and ready to fire by means of Single Action trigger.
 - The pistol can then be decocked with decocking lever **40**. Now the pistol is loaded, decocked and ready to fire with the double action trigger.
 - The Double Action Only pistol (DAO) and Double Action Kellermann pistol (DAK) is decocked and ready to fire.

Note:

- Double Action Only pistols (DAO) and Double Action Kellermann pistols (DAK) are not equipped with a decocking lever **40**. With each cocking or reloading, the hammer **29C/D** is caught by the hammer safety intercept notch.

5.6 Discharging a shot



WARNING!

Insufficient awareness of the dangers May lead to death or severe injuries

- Ensure that the target and the environment allow shots to be fired without danger.
- When discharging shots, ensure that neither your fingers, hands or any other parts of the body are located in front of, over or adjacent to the barrel muzzle or the ejection port.
- Never allow other persons to stand beside you where they might be struck by ejected cartridge cases.
- Always wear ear protection and safety glasses when shooting. Alert bystanders to the importance of wearing ear protection and safety glasses.
- Immediately stop shooting and unload the pistol if you suspect that a round has not been chambered properly, a case is jammed, a bullet is lodged in the bore or a discharge sounded or felt weak or abnormal (see Section 8.1).
- Never attempt to dislodge a blockage by firing another round.

Procedure:

1. Aim the pistol at a safe target.
2. Place finger on trigger and pull back the trigger to discharge the shot.
3. Keep the pistol aimed at the target and fire further shots as required.
4. Remove magazine and unload the pistol (see Section 5.8). If the pistol has been fired until the magazine is empty, slide **4** will be caught in the open position. If firing is to continue, reload the pistol (see Section 5.7).



WARNING!

Pistol is ready to fire

May lead to death or severe injuries

- After each discharge, Double Action/Single Action pistols are in cocked and ready-to-fire condition.
- If you wish to interrupt the shooting session, you must press the decocking lever * **40** down. The pistol is then in loaded, decocked and ready-to-fire condition.
- After each discharge, Double Action Only pistols (DAO) and Double Action Kellermann pistols (DAK) are decocked and ready to fire by means of the double action trigger.

* not applicable to DAO/DAK

5.7 Reloading during shooting

Slide is caught in the open position.



WARNING!

**Insufficient awareness of the dangers
May lead to death or severe injuries**

- Never let the pistol out of your hands.
- Keep the pistol pointed at the safe target.

CAUTION!

**Magazine may fall out
Magazine may be damaged**

- Always catch the ejected magazine using your free hand.

Procedure:

1. Remove the empty magazine (see Fig. 2).
 - Hold one hand underneath the magazine.
 - Press magazine catch **43** down. The magazine is ejected and caught using the free hand.
2. Insert full magazine and ensure that it engages.
3. Thumb down slide catch lever **18** or draw back slide **4** to the stop and allow it to fly forward (see Section 5.5).
 - The pistol is loaded and ready to fire.
 - The pistol can also be decocked by means of decocking lever **40** (not applicable to DAO/DAK pistols).
 - The pistol is loaded, decocked and ready to fire.

5.8 Unloading the pistol

5.8.1 Unloading the pistol, magazine not empty



WARNING!

Pistol is ready to fire

May lead to death or severe injuries

- Never let the pistol out of your hands before it is unloaded.
- The pistol is loaded, a round is located in the chamber of the barrel.
- Execute the unloading cycle with only two fingers from the rear.
- Never place your hand over the ejection port of the slide.

Procedure:

1. Keep the muzzle of the pistol pointed in a safe direction.
2. For Double Action/Single Action pistols: Press decocking lever **40** down, the hammer **29** catches in the safety intercept notch. With Double Action Only and Double Action Kellermann pistols, hammer **29C/D** automatically registers in the safety intercept notch.
3. Press magazine catch **43** down and remove magazine (see Fig. 2).

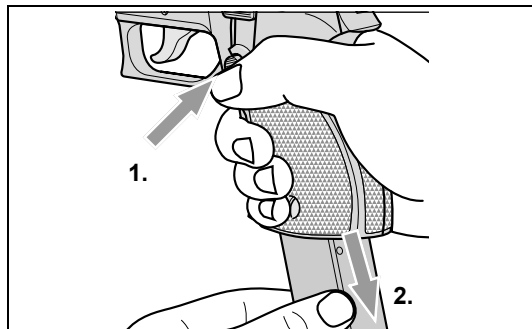

Fig. 2, Removing the magazine

4. Draw back slide **4** to the stop and thumb up slide catch lever **18** (see Fig. 7). The round is ejected and the slide is caught in the open position.
 5. Check visually and manually with a tool that the round was ejected and that no other round is chambered (see Fig. 3).
 6. Press slide catch lever **18** down. Slide **4** is impelled forward.
 7. Press decocking lever **40** down (not applicable to DAO/DAK pistols).
 8. Empty magazine.
 9. Pick up and clean ejected round.
- The pistol is unloaded and decocked.



WARNING!

**Pistol has not been cleaned sufficiently
May lead to death or severe injuries and
damage to the pistol**

- The pistol must be cleaned after every shooting session (see Section 7.3).

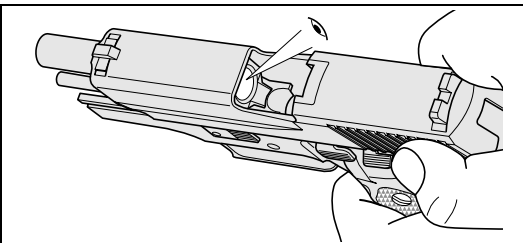

Fig. 3

5.8.2 Unloading the pistol, magazine empty, slide open



WARNING!

Pistol is loaded

May lead to death or severe injuries

- The pistol must not be put down and out of your hand until the magazine is removed and the pistol is unloaded.

Procedure:

- Keep the muzzle of the pistol pointed in a safe direction.
- Press magazine catch **43** down and remove magazine (see Fig. 2).
- Check visually and manually with a tool that the round was ejected and that no other round is chambered.
- Press slide catch lever **18** down. Slide **4** is impelled forward.
- Press decocking lever **40** down (not applicable to DAO/DAK pistols).
- Check the load state of the magazine.

The pistol is unloaded and decocked.



WARNING!

Pistol has not been cleaned sufficiently

May lead to death or severe injuries and damage to the pistol

- The pistol must be cleaned after every shooting session (see Section 7.3).

6 Sight correction

CAUTION!

Pistol may be damaged

- Sight corrections should only be carried out on an unloaded pistol by an armourer, gunsmith or an expert. A special tool (see Section 6.4) is required for this purpose. Any corrections should first be carried out on the rear sight **6**.

6.1 Sight correction for windage

6.1.1 Shifting the rear sight

Note:

- A special tool is required for this purpose (see Section 6.4).

Shifting the rear sight **6** by 0.5 mm to the right alters the point of impact to the right by approx. 8 cm at a 25 m range.

6.1.2 Shifting the front sight

Note:

- A special tool is required for this purpose (see Section 6.4).

Shifting the front sight **5** by 0.5 mm to the left alters the point of impact by approx. 8 cm to the right at a 25 m range.

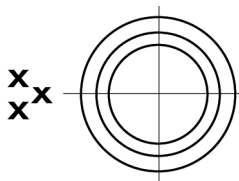

Fig. 4, Point of impact is on the left

6.2 Sight correction for elevation

Note:

- Any corrections should first be carried out on the rear sight **6**.

6.2.1 Changing the rear sight

Changing the rear sight **6** for a deeper rear sight (one front sight increment) alters the point of impact by approx. 4.4 cm at a 25 m range.

6.2.2 Changing the front sight

Changing the front sight **5** for a higher front sight (one front sight increment) alters the point of impact by approx. 2.2 cm at a 25 m range.

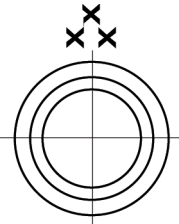

Fig. 5, Point of impact is high

6.3 Rear and front sight variants

6.3.1 Rear sight variants

Number	Height
04	5.24 mm
05	5.52 mm
06	5.80 mm
07	6.07 mm
08	6.35 mm
09	6.62 mm
10	6.90 mm

6.3.2 Front sight variants

Number	Height
05	6.01 mm
06	5.88 mm
07	5.74 mm
08	5.60 mm
09	5.46 mm
10	5.32 mm

6.4 Rear sight and front sight key

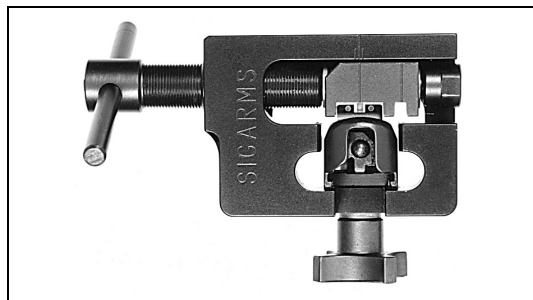

Fig. 6, Combined rear sight and front sight key

7 Pistol maintenance



WARNING!

Pistol is ready to fire

May lead to death or severe injuries

- The magazine must be removed from the pistol.
- Before stripping your pistol for cleaning, ensure once again that it is unloaded (see Section 5.8).
- Do not grasp slide 4 with your fingers.

7.1 Stripping the pistol

Procedure:

1. Unload the pistol (see Section 5.8).
2. Draw back slide 4 to the stop and arrest it in the open position by thumbing up the slide catch lever 18.

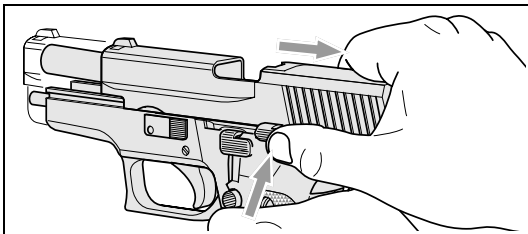

Fig. 7

3. Check that no round is chambered (see Fig. 3).
4. Thumb down takedown lever 16.

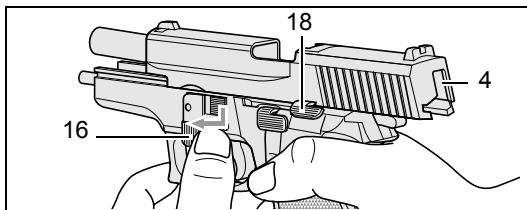

Fig. 8

5. Draw back slide 4 slightly to disengage the slide catch lever 18.
6. Hold slide 4 and allow it to glide forward.

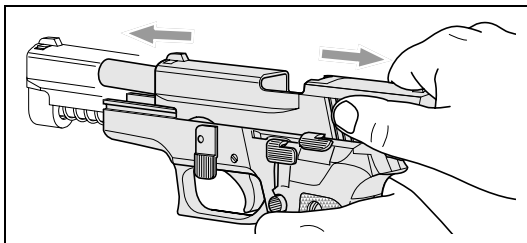

Fig. 9

7. Now slip the complete assembly (slide 4, barrel 1, recoil spring 3 and recoil spring guide 2) forward and off the frame.

7.1.1 Stripping the slide



CAUTION!

Slide and recoil spring unit are only connected loosely with each other
May lead to injuries and damage to the pistol

- The recoil spring 3 is cocked. Uncontrolled removal of recoil spring guide 2 can cause it and the recoil spring 3 to jump away. When stripping, control decompression of the preloaded recoil spring 3 with your hand.

Procedure:

1. Push recoil spring guide **2** forward, raise it carefully and remove the recoil spring **3** with the recoil spring guide **2** from the slide **4**.
2. Remove the recoil spring from the recoil spring guide.

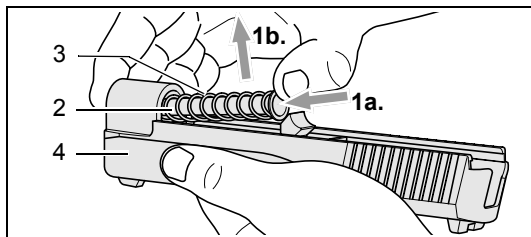

Fig. 10

3. Remove barrel **1** from the slide **4**.

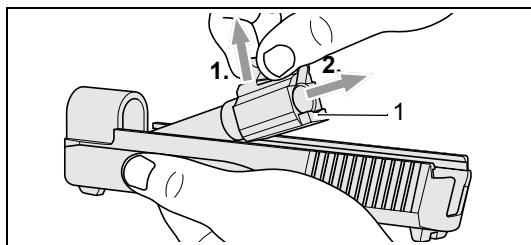

Fig. 11

Note:

- This level of stripping is sufficient to allow a thorough cleaning after shooting.
- Further dismantling of the pistol may only be carried out by qualified armourers and gunsmiths.

7.2 Disassembly of the magazine



CAUTION!

Magazine spring is compressed

May lead to injuries and damage to the pistol

- Do not carry out any work on the pistol near your face and hold magazine with the magazine floor plate pointing downwards.
- When removing the magazine spring, decock it slowly and with care.

Procedure:

1. Thump up floorplate insert **55** through the notch in the magazine floor plate **54** by means of a pin punch (diameter 3 mm or 4 mm).
2. Push the magazine floor plate forward and pull it off.

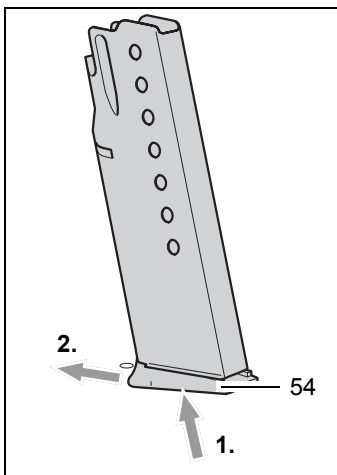

Fig. 12, Magazine

7.3 Cleaning the pistol

CAUTION!

Pistol may be damaged

- Never clean barrel **1** from the muzzle end and do not use a steel wire brush as it can destroy the smooth surface of the barrel. Use a suitable cleaning rod and a brush of matching calibre (see Section 11).
- Solvents can be harmful to the surface finish of the pistol. Read the manufacturer's indications and warnings before using solvents or cleansers.

Procedure:

1. Lubricate the cleaning brush with gun oil and insert it into the barrel **1** via the chamber. Use brush to carefully remove all powder residues and dirt in the barrel and chamber.
2. Wipe powder residues and oil from the barrel bore and chamber with cleaning patches.
3. Clean external surfaces of barrel with a brush dipped in gun oil.
4. Remove dirt from metal guide in the frame **15**, inside and outside of slide **4**, locking insert **17**, recoil spring guide **2** and recoil spring **3** with a brush and cleaning patch and then wipe down with a cloth impregnated with gun oil or gun grease.
5. Lightly oil bores of barrel and chamber. Remove any excess lubricant.

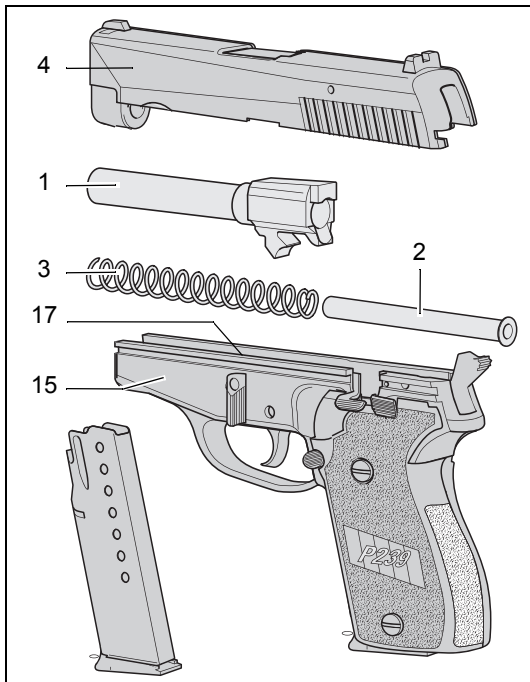

Fig. 13, Stripping weapon for cleaning

7.4 Assembling the pistol

Procedure:

1. Check that there is no foreign matter inside the pistol.
2. Check that serial number, slide number and frame number tally.

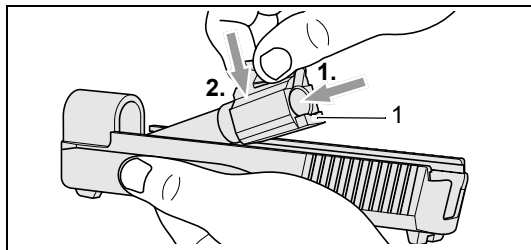

Fig. 14

3. Insert the barrel 1 into the slide 4.



CAUTION!

Slide, recoil spring guide and recoil spring are only connected loosely with each other. May lead to injuries and damage to the pistol.

- When recoil spring 3 is inserted into slide 4, it becomes preloaded. If the recoil spring guide 2 is not carefully installed in slide, it can fly out together with the recoil spring and injure you or someone in your vicinity.

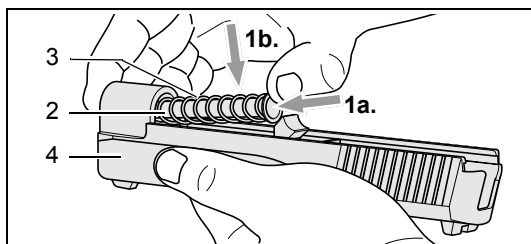

Fig. 15

4. Slide the recoil spring 3 with the smaller diameter on the recoil spring guide 2 first.
5. Thumb down takedown lever 16.
6. Insert recoil spring guide 2 and recoil spring 3 into slide 4.

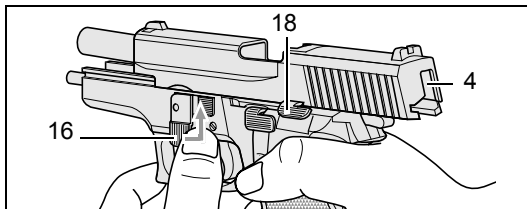

Fig. 16

7. From the front, slip assembled slide onto the guide rails of frame 15.
8. Draw back slide to the rear stop. Thumb up slide catch lever 18 to arrest slide 4 in its open position.
9. Flip up the takedown lever 16 counter-clockwise.
10. Press slide catch lever 18 down; slide 4 is impelled forward.
11. Press decocking lever 40 down (not applicable to DAO/DAK pistols).

Note:

- The pistol is unloaded and decocked.

7.5 Verification of functions

Note:

- Verification of functions must be conducted on the assembled pistol:
 - to identify causes of malfunction,
 - after completion of repairs,
 - and after each cleaning and assembly of the pistol.

Procedure:

1. Make sure that the magazine is removed and the pistol unloaded (see Section 5.8).
2. Check the elasticity of the recoil spring **3** and the smoothness of the slide **4** (no jamming).
 - Draw back slide to the stop and allow it to fly forward.
 - Check that slide is impelled forward with sufficient energy and that it engages.
 - Repeat the verification test.
3. Check the double-action trigger (DA).
 - With hammer **29** decocked, pull trigger **20** through.
 - Check that hammer cocks and that at the end of trigger travel, it strikes firmly forward and comes to rest in the safety intercept notch.
4. Check trigger travel and trigger interruption.
 - With hammer **29** decocked and trigger **20** pulled through, draw back slide **4** to the stop and release it.
 - Check that hammer **29** is restrained in its cocked position (trigger remains pulled through) (With DAO/DAK pistols, the decocked hammer **29C/D** must register in the safety intercept notch).
5. Check simple trigger function (SA). (Not applicable to DAO/DAK pistols).
 - Release trigger.
 - Check that trigger bar **22** re-engages and whether hammer **29** drops when the trigger is pulled again.
6. Check function of decocking lever **40** and safety intercept notch on hammer **29**.
 - Cock hammer **29** and decock it with decocking lever **40** without touching trigger **20** (not applicable to DAO/DAK pistols).
 - Check that hammer **29** is arrested in the safety intercept notch before reaching its forward end position and trigger is guided to the rest position.
7. Check slide catch lever **18**.
 - Insert empty magazine, draw back slide **4** to the stop and release it.
 - Check that slide remains caught in its rearmost position.
 - Press slide catch lever down.
 - Check that slide is released and impelled forward with sufficient energy.
 - Press decocking lever **40** down (not applicable to DAO/DAK pistols).
 - Remove magazine.
8. Inspect magazine.
 - Check condition of the magazine tube **51** for signs of damage or dirt (lips and floor plate).
 - Check that the magazine floor plate **54** is properly secured.
 - Check free movement and spring action of feeder **53**.
 - Check smooth insertion of magazine into frame **15**.
 - Check magazine catch **43** for clean engagement and release.

9. Inspect external appearance of the pistol.
- Check front sight **5**, rear sight **6**, grip plates **48/49** and takedown lever **16** for damage and dirt.
 - Check that rear sight, front sight and grip plates are firmly secured.
10. Verification of numbered components.
- Check that serial numbers of barrel **1**, slide **4** and frame **15** correspond.

7.6 Care of the pistol



CAUTION!

Inadequate care of the pistol

May lead to injuries and damage to the pistol

- Always keep your pistol in immaculate condition and in good working order.
- Always clean your pistol after use.
- Never modify or repair parts of your pistol yourself.
- Have your pistol checked once every 12 months by a qualified gunsmith or armorer because defects, wear, corrosion, etc. are not always visible from the outside.
- For repairs or service work, however, we recommend that you return your pistol to the manufacturer who always holds a full range of spare parts in stock.
- If you order spare parts without returning the pistol, you are responsible for ordering the correct part and its correct fitting by a qualified gunsmith or armorer.

The manufacturer and the importer cannot be held liable for faults in the pistol or malfunctions if the pistol has been modified or non-original parts have been fitted or repairs have been carried out by third parties.

8 Pistol service and repairs

8.1 Cause and correction of malfunctions

Pistol maintenance (cleaning and inspection) according to the instructions can prevent malfunctions.

Should, nevertheless, a malfunction occur during shooting, proceed as follows:



WARNING!

Uncontrolled discharge of shot May lead to death or severe injuries

- Hold pistol pointed in the firing direction (safe direction) and keep your finger off trigger **20** while you carry out the operations described in the following.

Procedure:

1. Remove and safeguard the magazine.
2. Draw back slide **4** to the stop and arrest it in the open position by thumbing up the slide catch lever **18**.
3. Verify (visually or with a tool) that there is no bullet, round, case or foreign body in the chamber or barrel bore (see Fig. 3).
If a projectile is lodged in the bore, strip the pistol (see Section 7.1) and have the blockage removed with a suitable tool by a qualified gunsmith.
4. Remove all rounds, cases or foreign bodies. Clean, lubricate and assemble the pistol (see Section 7.3 and 7.4).
5. Have the pistol inspected by an armourer or gunsmith.

Assembly/Malfunction	Potential Cause	Potential Remedy
Ammunition feed: No round chambered.	Magazine not properly inserted, deformed or dirty.	Insert magazine properly or replace it.
	Pistol or rounds dirty or too heavily greased.	Strip, clean and lubricate pistol (see Section 7.1 to 7.4).
	Incorrect ammunition.	Replace ammunition.
	Pistol defective.	Repair by manufacturer.
Slide: Slide does not close properly.	Recoil insufficient because of fouling.	Strip, clean and lubricate pistol (see Section 7.1 to 7.4).
	Incorrect ammunition.	Replace ammunition.
	Pistol defective.	Repair by manufacturer.
Case ejection: Spent case sticks in chamber or jams in ejection port.	Incorrect or underloaded ammunition.	Replace ammunition.
	Pistol defective.	Repair by manufacturer.
Misfire: Hammer strikes, but no discharge.	Firing pin sticking in its guide.	Strip, clean and lubricate pistol (see Section 7.1 to 7.4). Have pistol checked by armourer.
	Defective ammunition.	Manually cycle slide to chamber new round.
	Pistol defective.	Repair by manufacturer.

8.2 Safekeeping and storage of the pistol



WARNING!

Uncontrolled discharge of shot May lead to death or severe injuries

- Always store your pistol unloaded and in cleaned condition.
- Store your pistol separate from its ammunition and under lock and key. The pistol and ammunition must not be accessible to children and other inexperienced or unauthorised persons.

8.3 Shipping the pistol

Note:

- Familiarise yourself fully with regional legislation governing the shipping and transportation of firearms.

Procedure:

1. Check the pistol to ensure that it is unloaded and decocked.
2. Pack the pistol well (if possible in its original packaging) to prevent damage in transit.
To prevent the pistol being recognised as such during shipping, wrap the original packaging in a second outer layer. Do not include any other accessories in the shipment.
3. Enclose a letter stating the following:
 - your full name
 - your full address (mention street, not P.O. Box)
 - your daytime telephone number
 - model and serial numbers of the pistol

- detailed description of the problem encountered or the service work to be performed.
4. Send the pistol properly insured and carriage-paid (packages without correct postage will not be accepted) to:
 - the sales outlet from which you purchased the pistol
 - the local appointed J. P. Sauer & Sohn dealer
 - the J. P. Sauer & Sohn agent (importer) for your country
 - if there is no local appointed Sauer & Sohn dealer or Sauer & Sohn agent in your country, to J. P. Sauer & Sohn GmbH.

9 Product line

- Pistols for government agencies and the military
- Sport pistols
- Precision rifles (sniper)
- Hunting rifles
- Target rifles
- Accessories for pistols and rifles

10 Disposal

- Strictly observe any current national legislation governing the disposal of handguns.
- Provided this is not contrary to current national legislation, we recommend shipping the pistol to one of the addresses listed under Section 8.3.
- When shipping the pistol, strictly observe the instructions listed under Section 8.3.

11 Technical data/types/accessories

Technical Specifications	P 239		
Calibre	9 mm Para	.40 S&W	.357 SIG
Length, overall	173 mm	173 mm	173 mm
Height, overall	131 mm	131 mm	131 mm
Width, overall	31 mm	31 mm	31 mm
Barrel length	92 mm	92 mm	92 mm
Rifling lead	250 mm	380 mm	406 mm
No. of grooves	6	6	6
Sight base	136 mm	136 mm	136 mm
Weight, excl. magazine	780 g	868 g	868 g
Magazine weight, empty	70 g	70 g	70 g
Trigger pool DA/DAO/DAK, approx.	55 N (5,5 kg)	55 N (5,5 kg)	55 N (5,5 kg)
Trigger pool SA, approx.	35 N (3,5 kg)	35 N (3,5 kg)	35 N (3,5 kg)
Trigger pool SA, approx.	20 N (2,0 kg)	20 N (2,0 kg)	20 N (2,0 kg)
Magazine capacity/Rounds	8	7	7

Subject to change without notice

Standard version

- SA/DA trigger pool
- Solid bolt* of stainless material, black

Alternative versions

- DAO trigger system
- DAK trigger system
- Solid bolt* of stainless material, bright or black black plastic-coated

Accessories (see also the current accessories catalogue)

- Spare magazines (9 mm Para) 8/10 rounds
- Spare magazines (.40 S&W, .357 SIG) 7 rounds
- Cleaning kit
- Rear sight and front sight key
- Micrometer rear sight
- SIGLITE sights
- Wooden grips
- Holsters
- Carrying cases
- Trigger tongue long

* Bolt 4 made from one piece.

12 Spare parts

Note:

Illustration of spare parts list, see Fig. 17

Required specifications when placing spare part orders

- Pistol model (calibre, type)
- Pistol serial number
- Item number and index
- Part designation

Index explanation

- C = P 239 DAO
- D = P 239 DAK
- * = not for P 239 DAO/DAK



WARNING!

Uncontrolled discharge of shot

May lead to death or severe injuries

- Never use a standard hammer **29** in a DAO/DAK pistol.

Item Designation

- 1 Barrel
- 2 Recoil spring guide
- 3 Recoil spring
- 4 Slide
- 5 Front sight
05/06/07/08/09/10
- 6 Rear sight
04/05/06/07/08/09/10
- 7 Firing pin bolt
- 8 Extractor spring
- 9 Extractor bolt
- 10 Extractor
- 11 Firing pin
- 12 Firing pin trigger
- 13 Safety lock
- 14 Safety lock spring
- 15 Frame
- 16 Takedown lever
- 17 Locking insert
- 18 Slide catch lever
- 19 Slide catch lever spring
- 20 Trigger
- 21 Trigger pivot
- 22 Trigger bar
- 22D Trigger bar DAK
- 23 Trigger bar spring
- 24 Sear
- 24D Sear DAK
- 25 Sear spring
- 25D Sear spring DAK
- 26 Sear and safety lever axle
- 27 Roll pin, heavy

Item Designation

- 28 Safety lever
- 28D Safety lever DAK
- 29 Hammer
- 29C Hammer DAO
- 29D Hammer DAK
- 30 Hammer pin
- 31 Hammer pivot pin
- 32 Ejector
- 33 Hammer strut
- 33D Hammer strut DAK
- 34 Mainspring
- 35 Hammer strut roll pin
- 36 Mainspring seat
- 37 Hammer stop
- 38 Return spring
- 39 End stop pin
- 40* Decocking lever
- 41* Decocking lever bearing
- 42* Decocking lever spring
- 43 Magazine catch
- 44 Support plate
- 45 Magazine catch spring
- 46 Magazine catch stop
- 47 Catch stop spring
- 48 Grip plate, right
- 49 Grip plate, left
- 50 Grip plate screw
- 51 Magazine tube
- 52 Magazine spring
- 53 Feeder
- 54 Magazine floor plate
- 55 Floorplate insert

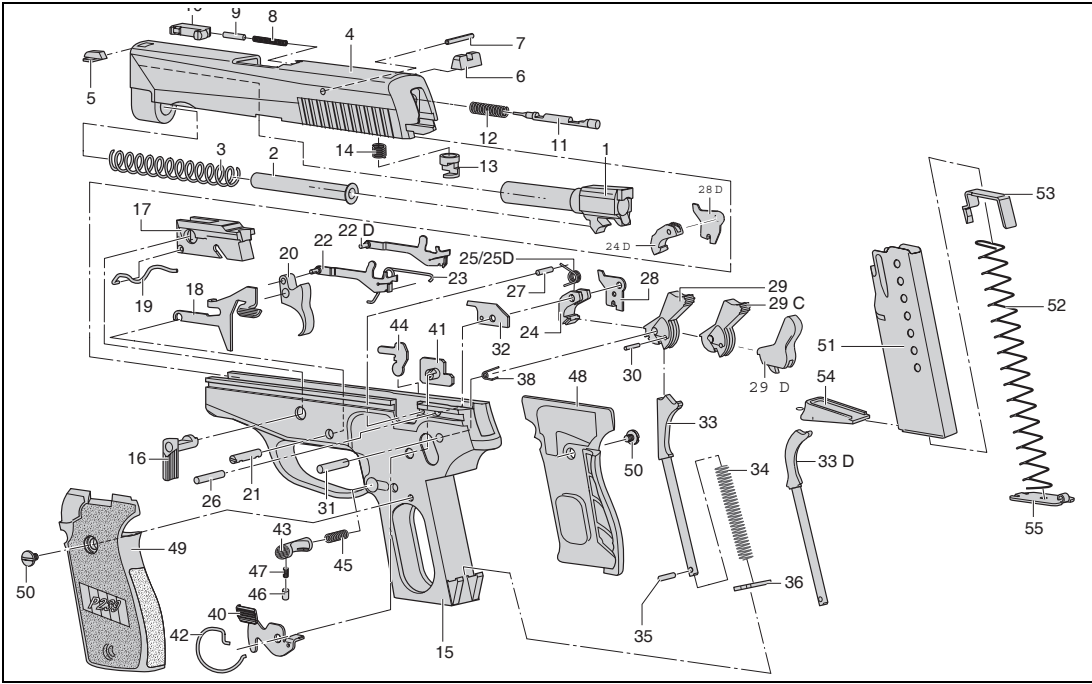

Fig. 17, Spare parts P 239



SIGSAUER

SIGSAUER

J. P. Sauer & Sohn GmbH
gegr. 1751

Sauerstr. 2-6

D-24340 Eckernförde

Germany

Telephone +49 4351 471 100

Fax +49 4351 471 160

www.sigsauer.de